

ROADMASTER

Always Setting New Standards for the Towing Industry

FREE!
NEW EXTENDED
WARRANTY
AVAILABLE
30 DAY DEADLINE

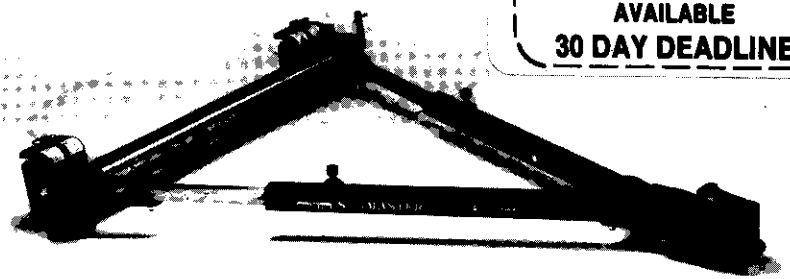

Precision Folding Tow Bar

YOU HAVE PURCHASED THE FINEST TOW BAR MADE

IMPORTANT DOCUMENT

PACKET TO BE REMOVED BY
VEHICLE OWNER **ONLY**
CONTAINS:

**WARRANTY & REGISTRATION CARD
OPERATING INSTRUCTIONS
& INFORMATION PERTAINING TO THE
PROPER USE OF THIS PRODUCT**

ROADMASTER, INC.
Manufacturers of Quality RV Products

STOWMASTER™ 5000

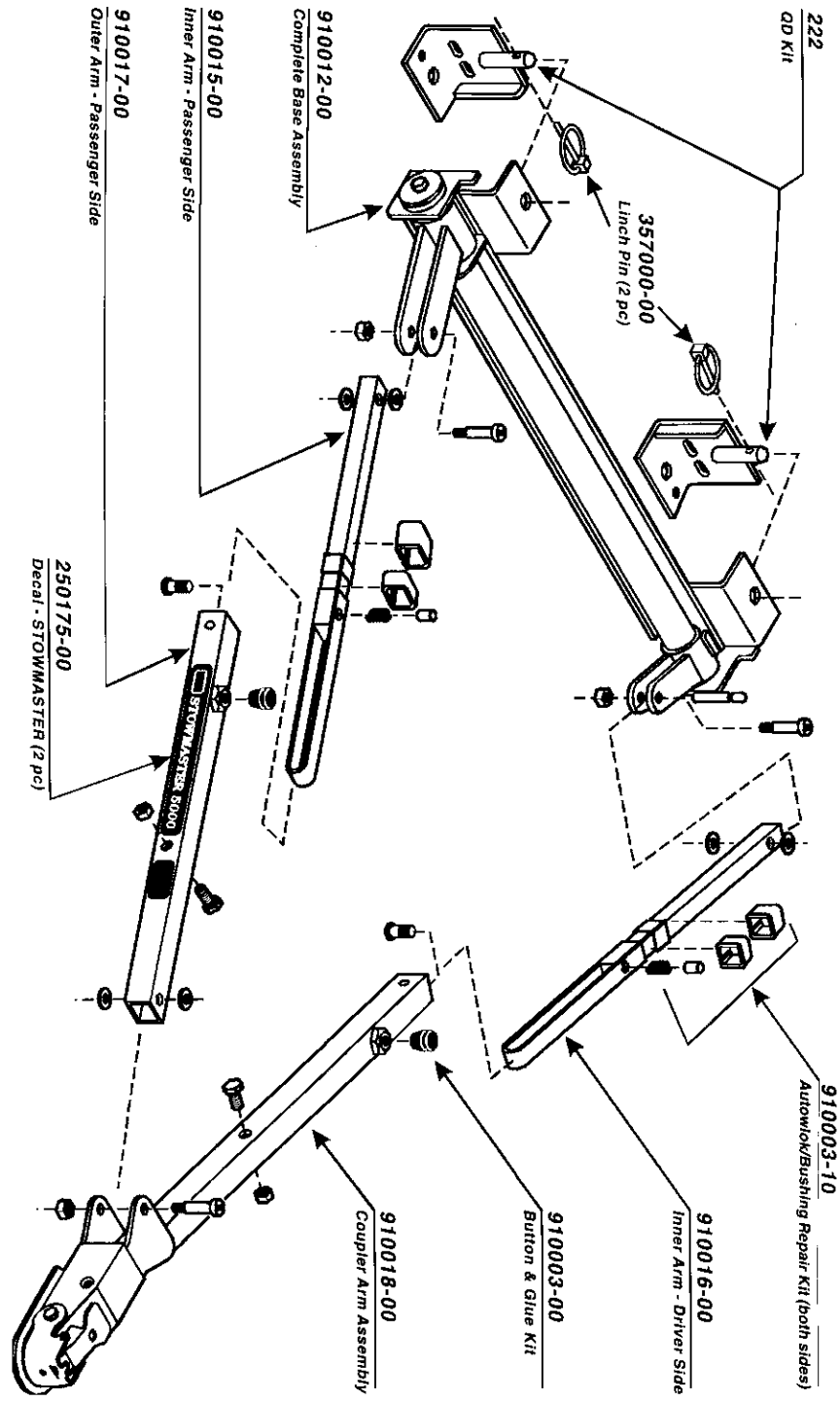

R O A D M A S T E R

*Congratulations on your new **STOWMASTER™** tow bar...and **THANK YOU**. You have purchased the finest tow bar made...bar none! Quality materials, computer technology and our reputation for craftsmanship have gone into each of our precision folding tow bars. Each of our products is designed for safe, trouble-free towing. Your safety is important to us. This booklet was written with your safety in mind.*

Before using your tow bar, read this booklet. Understand how to install & maintain your tow bar and carefully follow all the safety precautions. Enclosed you will find a set of installation, operating & maintenance instructions and safety precautions. Read and carefully follow these instructions. Remember, proper installation and use of the product is the sole responsibility of the purchaser. Improper installation, use or maintenance may result in death, personal injury, property damage or an accident.

A good time to check your mounting brackets is during your regular vehicle maintenance check-ups such as an oil change, brake check or tire rotation. Don't forget to keep your tow bar clean and lubricated on a regular basis. We offer a silicone spray specifically for this purpose. Using our vinyl tow bar cover will help keep your tow bar free from dirt and road grime assuring easy hook-up and operation. Safety cables or chains are required by law in most states. Follow our safety cable installation in this booklet.

Finally, don't forget to fill-out and mail back your warranty card. It's important to register your tow bar with us and if you mail your warranty card to us within 30 days of the purchase date, we'll extend your warranty to a total of two years at no additional charge.

ROADMASTER, INC.

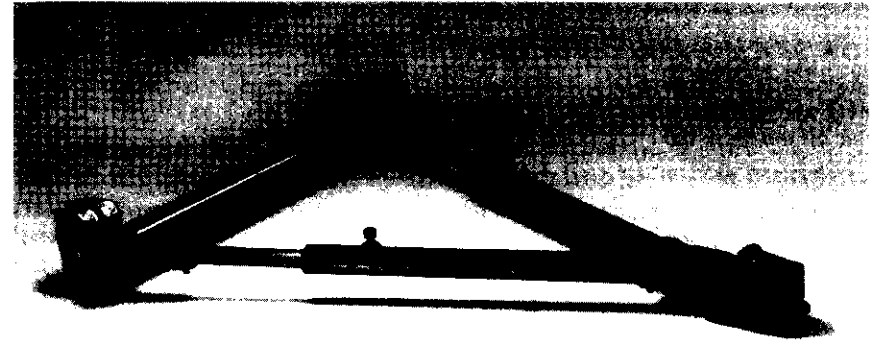

STOWMASTER™ 5000 PRECISION FOLDING TOW BAR

This booklet contains information concerning:

- **THANK YOU & INTRODUCTION** inside front cover
- **TABLE OF CONTENTS** pg. 1
- **10 MUSTS FOR TOWING SAFETY** pg. 2
- **INSTALLER MUSTS FOR TOWING SAFETY** pg. 3
- **CAUTION NOTICES** pg. 4
- **INSTALLATION INSTRUCTIONS** pg. 5,6
- **SAFETY CABLE INSTALLATION** pg. 6
- **HERE'S HOW IT WORKS** pg. 7,8
- **CARE & MAINTENANCE** pg. 8,9
- **COUPLER INFORMATION** pg. 10
- **WARRANTY INFORMATION** pg. 11
- **FREE BONUS INFORMATION** pg. 12
- **ROADMASTER INFORMATION** inside back cover
- **STOWMASTER PARTS BREAKDOWN** back cover

10 MUSTS FOR TOWING SAFETY

- 1. TOW BAR MUST BE LEVEL WITH THE BALL HITCH ON THE MOTORHOME**
Towing with an upward or downward slope of the tow bar puts undue strain on the base-plate and the ball mount. Driving over sharp inclines or declines could force the coupler off the hitch ball.
- 2. STEERING MUST BE UNLOCKED AND FREE TO TURN WHEN TOWING**
Failure to do so can result in severe tire and equipment damage. Steering wheel must be free to turn when towing.
- 3. DRIVER MUST NOT BACK UP MOTORHOME WITH VEHICLE ATTACHED**
Backing up with towed vehicle attached easily causes the vehicle to "jack-knife" and will damage the tow bar, mounting bracket, hitch, the towed vehicle front end and/or rear of the motorhome. This is the primary cause of tow bar "A" frame damage and will void the warranty.
- 4. THE BALL MUST BE 2" TO PROPERLY FIT THE TOW BAR COUPLER**
In addition, the ball shank diameter must match the hole size in the ball mount. If it is too large for the threaded shank of the ball, the stress and vibration during towing could cause the ball to loosen and disengage from the coupler.
- 5. OWNER MUST KEEP THE TOW BAR CLEAN AND WELL LUBRICATED**
As is the case with most precision equipment, frequent cleaning and care results in better prolonged service. Details for cleaning & lubricating your STOWMASTER tow bar are outlined in the attached section titled "Care and Cleaning Tips".
- 6. OWNER MUST INSPECT ALL MOUNTS, BRACKETS AND FASTENERS**
Frequent inspection of ALL bolts and metal components is necessary to avoid problems on the road. Frequency is determined by the hazardous road conditions, climate and amount of towing you do.
- 7. OWNER MUST FILL OUT & MAIL THE WARRANTY REGISTRATION CARD**
It is IMPORTANT that you send in a completely filled out registration card as soon as possible. The information is needed in case we must contact you for updates, recalls and to verify your warranty.
- 8. OWNER MUST CHECK MANUFACTURER'S INSTRUCTIONS FOR TOWING**
Some vehicles require a transmission lube pump, axle disconnect, driveline disconnect or free-wheeling hubs to tow without damaging equipment. Failure to properly equip vehicle will result in severe damage to the transmission. Steering wheel must be unlocked for towing. Check manufacturer's specifications for proper procedure to prepare vehicle for towing. Be sure your vehicle is towable before taking it on the road.
- 9. OWNER MUST NEVER TOW VEHICLE WITH A LIGHTER VEHICLE**
Towing a vehicle equipped with a tow bar using a lighter weight vehicle as the tow vehicle will cause the rear vehicle to over-ride the front vehicle, resulting in "jack-knifing", "leap-frogging", "fish-tailing" or other damage provoking predicament. Serious damage to both vehicles and the towing system equipment could result.
- 10. OWNER MUST ALWAYS USE SAFETY CABLES OR CHAINS WHEN TOWING**
ROADMASTER Safety Cables are legal in all states.

FAILURE TO FOLLOW THESE INSTRUCTIONS CAN RESULT
IN DEATH, PERSONAL INJURY OR PROPERTY DAMAGE

INSTALLER MUSTS FOR SAFETY

- INSTALLER MUST SHOW OWNER HOW TO OPERATE THE TOW BAR PROPERLY**
Carefully read the section "*Here's How It Works*" and familiarize yourself with the features of the tow bar. Demonstrate it and have the new OWNER do a few "Practice Runs" himself. You not only impress him with your thoroughness, but will start him off on a safer and happier towing experience.
- INSTALLER MUST CAUTION OWNER TO USE CLASS III HITCH & 2" BALL ON THE RECEIVER**
The hitch and ball must have a minimum capacity of 5000 lbs.(GVWR) each. Also be sure that the shank of the ball fits snugly in the ball mount hole. A loose fitting ball shank could be hazardous if the ball should loosen and disconnect from the mount due to stress or vibration during towing.
- INSTALLER MUST BOLT THE TOW BAR TO A BRACKET ATTACHING TO THE TOW VEHICLE'S FRAME OR UNIBODY**
The **STOWMASTER** tow bar is designed as a bolt on device only. Virtually all vehicles require a mounting bracket assembly that is connected safely to the frame, unibody or chassis and extends beyond the bumper. **Under no circumstances should the tow bar be welded to the vehicle, nor should any of the pre-punched mounting holes be altered.** In fact, any welding or altering of the tow bar will void the Owner's Warranty. Using a kit designed by **ROADMASTER** takes the burden of doubt out of the installer's hands.
- INSTALLER MUST ADVISE OWNER TO ADD PROPER SAFETY CABLES**
A frame to frame safety cable or chain hookup is legal in ALL states that require them. Although chains are acceptable, most towing veterans prefer cables. **ROADMASTER** manufactures safety cable kits designed especially for tow bar security and safety. Cables are easier, cleaner and lighter to handle than chains. Since laws vary state by state, check owner's home state regulations for exact requirements that may apply.
- INSTALLER MUST STRESS IMPORTANCE OF OWNER SENDING IN WARRANTY**
New owners are to be urged to send in the **Warranty Registration Card** as soon as possible. This will enable **ROADMASTER, INC.** to expedite any claim or update important information concerning the **STOWMASTER** tow bar.
- INSTALLER MUST READ INSTRUCTIONS THOROUGHLY BEFORE MOUNTING THE TOW BAR**
Proper mounting of the tow bar is of utmost importance. Proper centering and height positioning of the tow bar will give the owner a safe, dependable and trouble-free towing system.
- INSTALLER MUST BE SURE VEHICLE IS SUITABLE OR ADAPTABLE FOR TOWING**
Not all vehicles can be safely towed as manufactured. A few models are not towable under any conditions and most others with automatic transmissions require additional equipment.
- INSTALLER MUST NOT USE THE TOW BAR BASE AS A GROUND IF WELDING ON BAR, BRACKET OR VEHICLE.**
(STOWMASTER ONLY) Connecting a ground to the A-frame of the **STOWMASTER** tow bar will cause current to flow through the locking spring which will detemper the spring and destroy the locking mechanism. **Under no circumstances should the tow bar be welded to the vehicle, nor should any of the pre-punched mounting holes be altered.** In fact, any welding or altering of the tow bar will void the Owner's Warranty.

CAUTION!

NEVER BACK UP WHEN TOWING YOUR VEHICLE

Backing up with a ball mount towing system, while the towed vehicle is attached, will easily "jackknife" the vehicle being towed. This will result in damage to the towed vehicle, hitch, tow bar assembly, and/or motorhome.

Roadmaster, Inc. assumes no responsibility for any damage that is caused by improper use. Backing up with a towed vehicle is considered "improper use".

Tow Bar rating 5000 lbs.

The **STOWMASTER™ 5000** tow bar must be mounted upright as shown here.

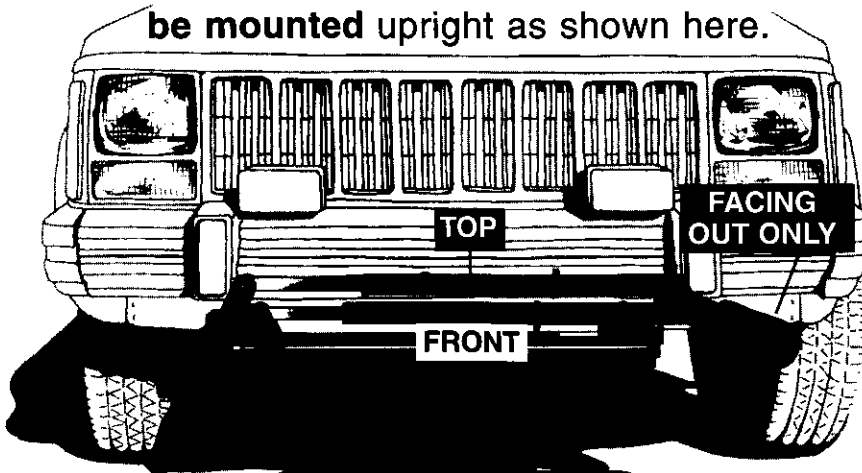

CAUTION

NEVER mount to vehicle with coupler facing any other way.

Do **NOT** tow your vehicle if mounted improperly!

FAILURE TO FOLLOW THESE INSTRUCTIONS CAN RESULT IN DEATH, PERSONAL INJURY OR PROPERTY DAMAGE

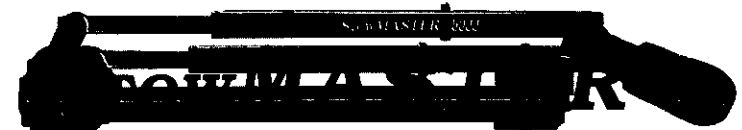

INSTALLATION INSTRUCTIONS

OWNERS AND INSTALLERS MUST READ THE INSTALLATION INSTRUCTIONS AND CAREFULLY NOTE THE WARNINGS!

Optional stabilizer bar may be required if vehicle's frame is torqued or twisted preventing the proper spacing of the tow bar mounting bracket holes.

PARTS LIST:
2 - BRACKET PLATES (A & B)
2 - SAFETY PLATES (C)
ALL PINS & BOLTS INCLUDED

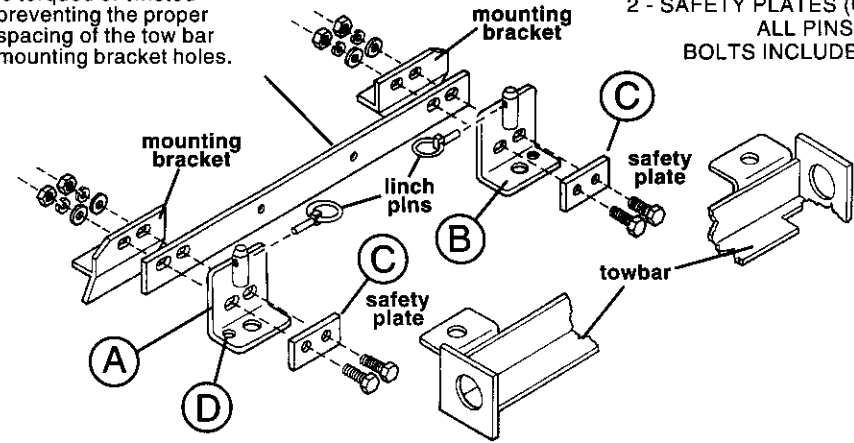

1 Take part "A" and mount it on the passenger side as shown, using the supplied 1/2" x 1-1/2" bolts, safety plate "C", flat washers, lock washers and nuts. Do not tighten - leave loose for now - they **will** be tightened later.

NOTE: Parts "A & B" have an extra hole "D" designed for safety cable attachment. Mount holes to outside.

2 The remaining part "B" is to be mounted to the driver side of the mounting bracket. Be sure that the corner hole "D", is on the outer side of the bracket parts "A & B" which must also have the vertical pin facing upward to properly mount the tow bar. Use the supplied 1/2" x 1-1/2" bolts, safety plate "C", flat washers, lock washers and nuts. Do not tighten - leave loose for now - they **will** be tightened later.

3 Now, mount the tow bar by lowering it so that the vertical pins of parts "A & B" extend upward through the top holes of the tow bar. At the same time be sure the lower vertical pins of the tow bar slide through the lower holes on parts "A & B".

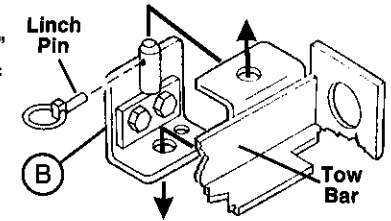

(continued on next page)

FAILURE TO FOLLOW THESE INSTRUCTIONS CAN RESULT IN DEATH, PERSONAL INJURY OR PROPERTY DAMAGE

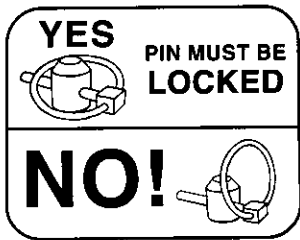

IMPORTANT: Towing vibrations will force the linch pins to wiggle out unless they are properly **LOCKED** in place over the Quick Disconnect pins. The proper locked position for the linch pins is illustrated above.

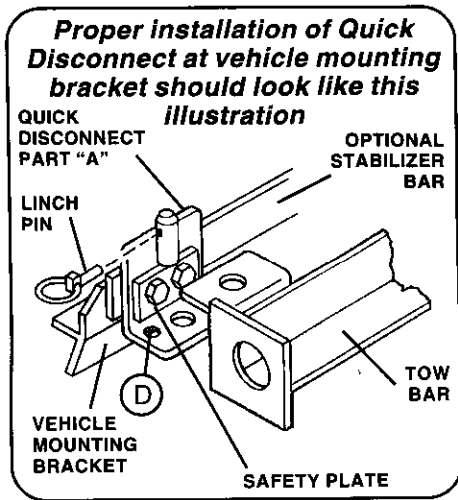

4 Linch pins **must** be inserted through the upper holes in parts "A & B" and **locked** as illustrated above, to keep the tow bar stabilized.
WARNING: Failure to install linch pins properly will result in tow bar malfunction, loss and damage to your vehicle and property, injury or even death. You will lose your car.

5 Now, torque all bolts to 78 ft./lbs. Attach safety cables to the holes "D" located to the outside of Quick Disconnect parts "A & B".
WARNING: Unless the safety cables are attached to the Quick-Disconnect mount properly, hole "D", the safety cables will not keep you from losing your towed vehicle in the event the tow bar comes off the Quick-Disconnect mount.

PROPER INSTALLATION OF SAFETY CABLES

Do NOT run cables between ball & coupler. Using OPTIONAL safety cable guide will help prevent pinched or frayed cables that are unsafe and will invalidate warranty.

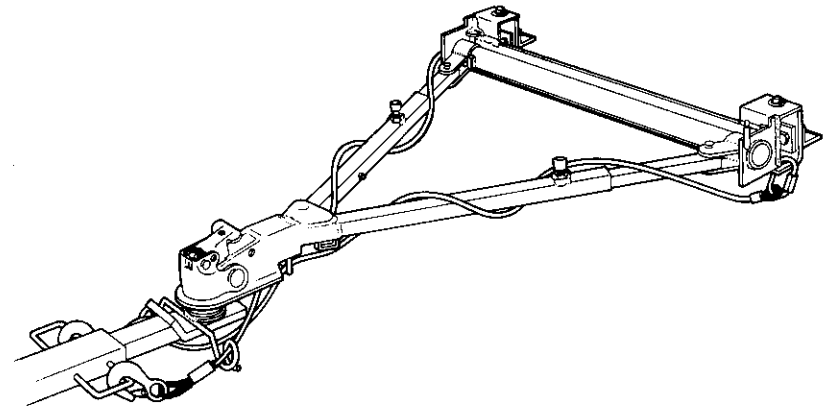
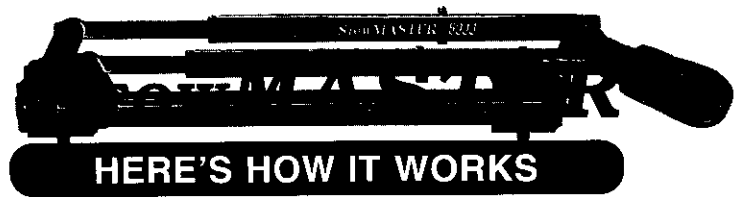
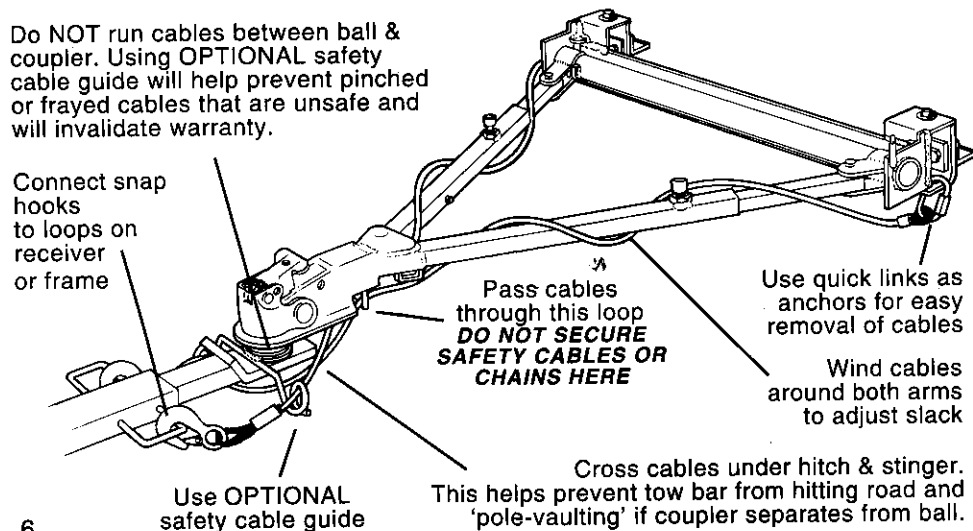

You are now the proud owner of the revolutionary tow bar with the exclusive "**AUTOWLOK**" System that **AUTOMATICALLY** locks your tow bar into towing position as you drive away. The telescoping "A" frame glides in & out on self-lubricating nylon bushings for easy set up or stowing.

IT'S A SIMPLE OPERATION, BUT HERE ARE A FEW HELPFUL HINTS TO HELP GET YOUR TOW VEHICLE CONNECTED OR DISCONNECTED IN SECONDS.

1. Drive your vehicle up to the rear of your motorhome (or towing vehicle) within 3 to 3-1/2 ft. from the hitch ball. Vehicle does not have to be on center. Remove the safety pin from the driver's side of the folded tow bar.

2. Swing the tow bar upward counter-clockwise to a vertical position and slide the driver's side arm to the extreme right hand side of the stainless steel spreader bar. Now, lower the "A" frame directly onto the hitch ball. Be sure to raise the lever on the coupler and slide it backwards, so that the coupler will seat firmly onto the ball. Also release both telescoping arms by pressing down the button on each arm. This will allow you greater flexibility in locating the ball with the coupler. Slide the coupler lever forward and down after the coupler is fully covering the ball. This will secure the coupler for towing.
ROADMASTER recommends using our optional coupler lock for added safety from accidental coupler disconnect and theft.

3. Attach your safety cables (or chains) and plug in your light wiring harness according to the supplier's instructions. Before towing your vehicle be sure the **steering is unlocked** and the transmission is in the proper position. **Check your manufacturer, Owners Manual or with your installer for the proper towing procedures or requirements**, which depends on the type of vehicle being towed.

Then simply get into your towing vehicle and drive away. Your **STOWMASTER** equipped vehicle will center itself and the **"AUTOWLOK"** System will snap into the lockout position.

4. To detach your towed vehicle, simply reverse the above procedure. After disconnecting the coupler, raise the tow bar into a vertical upright position. Now depress the locking button on the driver's side arm and allow it to compress fully. Then slide the driver's side arm across the round tube while lowering the coupler onto the stabilizer pin. *Do not release the passenger side button* as it allows the bar to be lowered directly onto the pin without any adjustment.

ROADMASTER recommends replacing at least one quick release pin with a padlock to prevent accidental release or theft.

FAILURE TO FOLLOW THESE INSTRUCTIONS CAN RESULT IN DEATH, PERSONAL INJURY OR PROPERTY DAMAGE

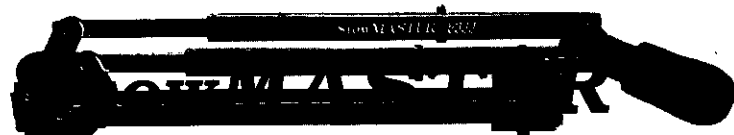

CARE & MAINTENANCE

Good equipment, with moving parts such as the **STOWMASTER** tow bar, requires lubricating and cleaning on a regular basis. When towing a vehicle at normal speeds, the tow bar is being subjected to "sand blasting" by road debris and particles of grit or dirt. The following tips will help you maintain the condition of your tow bar and prolong the life of your towing system.

Clean the entire surface of the tow bar with WD-40 or a similar product. Spray a generous amount into the "lube points" (as shown with arrows on the drawing on page 9). Cycle the tow bar several times. **Then completely wipe off the WD-40 with a clean dry cloth.** Allow the "lube points" to drain and then wipe clean.

(continued on next page)

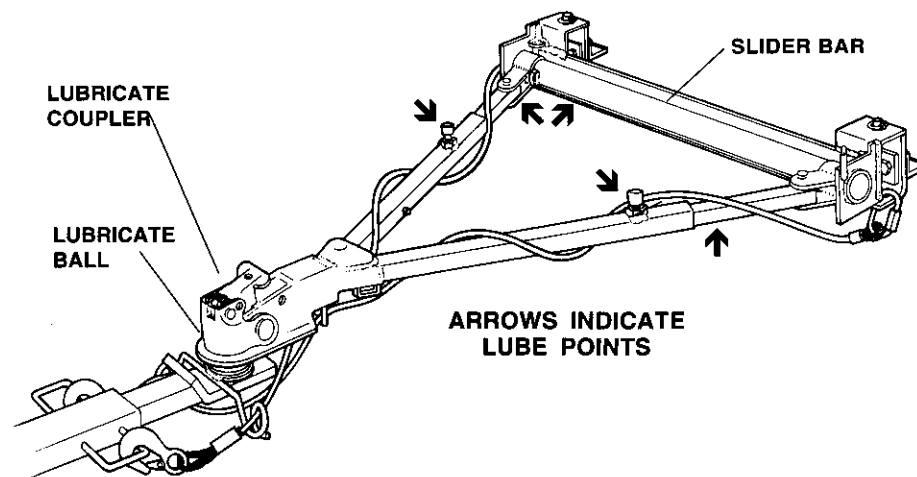

Use a **silicone lubricant** spray, such as **ROADMASTER's LUBEMASTER™** over the entire surface of the unit. Silicone lubricant will produce a protective film but will not attract dirt.

Now, spray **silicone lubricant** thoroughly on the working surfaces, especially on the stainless steel arms and slider bar.

- On the arms, depress the buttons and slide the outer sleeves in & out along the stainless surfaces of the inner arms.
- On the slider bar, hold the "A" frame upright in a vertical position and slide the movable arm back and forth along the stainless steel tube.

Movement of these components will allow the silicone to better penetrate the wear points & more thoroughly lubricate the tow bar.

Proper cleaning and lubrication of the tow bar will help prevent corrosion on your tow bar and provide smooth opening and closing when on the road.

NOTE: Silicone lubricant is safe for all painted surfaces and will help preserve the finish of the tow bar.

To remove scratches and restore luster on the stainless steel arms and slider bar we suggest that you use: Extra fine (0000) steel wool, 3M "Scotch Brite" (fine pad) or a similar product.

FAILURE TO PROVIDE PREVENTIVE CARE & MAINTENANCE CAN RESULT IN DEATH, PERSONAL INJURY OR PROPERTY DAMAGE

COUPLER INFORMATION SHEET

THE FOLLOWING IS A COPY OF ATWOOD COUPLER INFORMATION TAG THAT IS ATTACHED TO EACH COUPLER AND IS A NOTIFICATION WE ARE PASSING ON TO THE CONSUMER.

OPERATION INSTRUCTIONS

1. TO OPEN, PULL UPWARD ON LATCH HANDLE AND LIFT UNTIL YOU RAISE THE YOKE ABOVE THE NOSE OF THE COUPLER. (FIGURE 1)
2. MOVE HANDLE FULLY REARWARD SO THAT THE YOKE RESTS ON TOP OF THE COUPLER NOSE.
3. PLACE COUPLER ON BALL OF SAME DIAMETER AS COUPLER AND OF SAME OR GREATER CAPACITY.
4. WHEN BALL IS COMPLETELY NESTED IN SOCKET, PUSH LATCH FORWARD UNTIL YOKE DROPS OVER NOSE OF COUPLER AND THE LATCH HANDLE LEG TIPS FREELY INTO SLOTS ON TOP OF COUPLER. (FIGURE 2)
5. EXTEND JACK TO GROUND AND LIFT CAR/TRAILER 2-4" TO INSURE COUPLER IS SECURELY ATTACHED TO TOW BALL. RETRACT JACK BEFORE TOWING.
6. INSERT PADLOCK THROUGH LOCK HOLE IN YOLK FOR THEFT PREVENTION.

FIGURE 1

OPEN POSITION

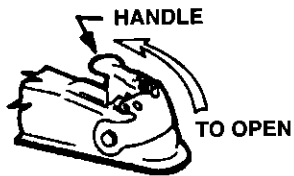
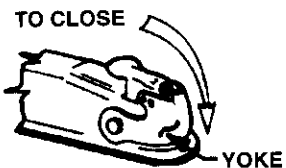

FIGURE 2

CLOSED POSITION



MAINTENANCE INSTRUCTIONS

LUBRICATE BALL SOCKET WITH EXTREME PRESSURE GREASE. LUBRICATE MOVING PARTS WITH SAE 30 OIL

! WARNING !

SAFE TOWING PRACTICE REQUIRES THE PROPER USE OF SAFETY CHAINS USED IN ACCORDANCE WITH INSTRUCTIONS PROVIDED BY THE TRAILER MANUFACTURER.

CHECK TO MAKE SURE THAT THE BALL HAS BEEN COMPLETELY INSERTED INTO THE BALL SOCKET AND THAT THE BALL CLAMP (INSIDE OF COUPLER) IS CLOSED AROUND THE UNDERSIDE OF THE TOW BALL AND THAT THE YOLK AND HANDLE IS IN THE CLOSED POSITION. THE LOADED WEIGHT OF THE TRAILER MUST NEVER EXCEED THE CAPACITIES MARKED ON THE COUPLER, TOW BAR OR HITCH.

CHECK THE COUPLER, HITCH AND BALL FOR DAMAGE OR WEAR BEFORE EACH USE. MAKE SURE THAT ALL PARTS OPERATE FREELY. REPLACE ANY COMPONENT IF WORN OR DAMAGED. FAILURE TO FOLLOW THESE WARNINGS AND OPERATIONS WILL RESULT IN SEPARATION OF TOW VEHICLE AND TRAILER WHICH CAN RESULT IN DEATH, PERSONAL INJURY AND PROPERTY DAMAGE.

INSTALLATION INSTRUCTIONS

REQUEST ATWOOD BULLETIN MPD85701 FOR COMPLETE INSTRUCTIONS ON COUPLER INSTALLATION, OPERATION AND MAINTENANCE. DO NOT ATTEMPT INSTALLATION WITHOUT BULLETIN.

ATWOOD MOBILE PRODUCTS
ROCKFORD, IL 61103
PH (815) 877-5700

WARRANTY INFORMATION

Please FILL OUT COMPLETELY. This information is a duplicate of the warranty card you filled out and sent to us. **THANK YOU.**

NAME: _____

ADDRESS: _____

CITY: _____ STATE: _____ ZIP: _____

PHONE: () _____

DATE: _____

TOW BAR
PURCHASED
FROM: _____
Dealer Name

ADDRESS: _____

CITY: _____ STATE: _____ ZIP: _____

PURCHASE PRICE: \$ _____

TOW BAR SERIAL # : _____

VEHICLE TO BE TOWED: (STOWMASTER MOUNTED)

MAKE: _____ YEAR: _____

MODEL: _____

SHIFT:
AUTOMATIC STANDARD 4WD

TOWING VEHICLE INFORMATION: (e.g. MOTORHOME)

MAKE: _____ CLASS: _____

MODEL NAME: _____ YEAR: _____

INSTALLER INFORMATION:

BUS. NAME: _____

ADDRESS: _____

CITY: _____ ST: _____ ZIP: _____

PHONE: () _____

ROADMASTER, INC.

5602 N.E. SKYPORT WAY PORTLAND, OR 97218

1-800-669-9690

THIS NOTIFICATION APPLIES ONLY TO COUPLER USAGE AND DOES NOT ALTER INDIVIDUAL ROADMASTER, INC. INSTRUCTIONS.
THE REFERENCE TO TRAILER USAGE DOES NOT APPLY TO STOWMASTER™ APPLICATION OF THE ATWOOD COUPLER. THE TOW BAR USAGE IS INTENDED ONLY FOR TOWING FOUR-WHEELED VEHICLES.

ROADMASTER FREE BONUS

EXTENDED WARRANTY

If you fill out & mail the warranty registration card within thirty (30) days from the date of purchase, we will extend the coverage to a total of **TWO (2) years** at no extra charge.

DON'T DELAY - MAIL IT TODAY TO EXTEND YOUR WARRANTY COVERAGE

Your warranty registration is an important record for **ROADMASTER** to keep in touch with you. It also enables us to expedite any future claim, update or recall that may arise concerning our products.

IMPORTANT FILL OUT - TEAR OFF & MAIL WITHIN 30 DAYS FOR THE EXTENSION

CAN'T LOCATE YOUR TOW BAR SERIAL NUMBER?

YOUR TOW BAR SERIAL NUMBER IS LOCATED ON A METAL LABEL LOCATED ON THE PASSENGER SIDE OF YOUR TOW BAR. YOU WILL NEED THAT NUMBER WHEN YOU FILL OUT YOUR TOW BAR WARRANTY INFORMATION.

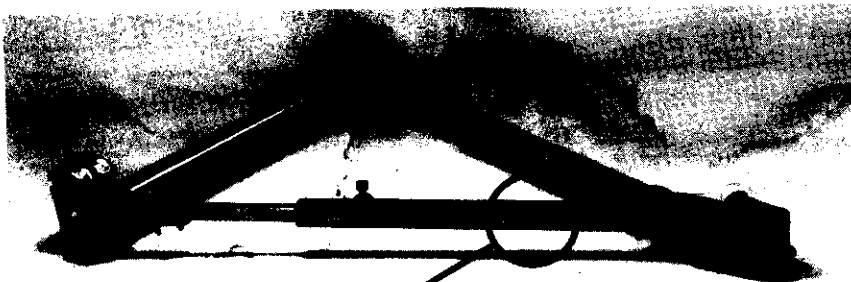

SERIAL NUMBER # _____

091095

ROADMASTER LIMITED WARRANTY

ROADMASTER, Inc. warrants to the original retail purchaser-consumer of this product that such product when used for its normal intended purposes is free of defects in workmanship and materials. This warranty, together with any and all warranties implied by law, shall be limited to a duration of one (1) year from the date of purchase by the original retail purchaser-consumer and is not transferable.

This warranty only covers failures due to defects in materials or workmanship which occur during normal and proper use and does not cover damage which occurs in shipment, backing up with "towed" vehicle attached or failures which are caused by products not supplied by ROADMASTER, Inc. or failures which result from normal wear, misuse, abuse, neglect, mishandling, misapplication, faulty installation, setup adjustments, improper maintenance, alteration, maladjustment, modification, commercial use or service of the product by anyone other than ROADMASTER, Inc.. Furthermore, this warranty does not apply to any product or material or part which has been installed, maintained or used contrary to the operating, maintenance or installation instructions and shall not apply to any parts or materials used in the installation that were not supplied with the product in the original carton or to any damage which said parts or materials may cause.

THIS WARRANTY DOES NOT COVER, AND IS INTENDED TO EXCLUDE, ANY LIABILITY ON THE PART OF ROADMASTER, INC., WHETHER UNDER THIS WARRANTY OR UNDER ANY WARRANTY IMPLIED BY LAW, FOR ANY INCIDENTAL OR CONSEQUENTIAL DAMAGES. SOME STATES DO NOT ALLOW THE EXCLUSION OR LIMITATION OF INCIDENTAL OR CONSEQUENTIAL DAMAGES, SO THE ABOVE LIMITATION OR EXCLUSION MAY NOT APPLY TO YOU.

RESPONSIBILITY OF ROADMASTER, INC.

With proof of date of purchase by the consumer, ROADMASTER's responsibility under this warranty shall be limited to the repair or replacement (at its option) of any product or part which is actually defective at no charge to the consumer except for shipping and/or mailing charges. In no event shall ROADMASTER's liability under any claim or theory exceed the purchase price of the equipment in respect of which damages are claimed. No agent, representative, dealer or employee has the authority to alter or increase the obligations or limitations of this warranty.

RESPONSIBILITY OF THE PURCHASER

In order to qualify for this warranty, the purchaser must completely fill out and, within thirty (30) days of purchase, send to ROADMASTER, Inc. the attached warranty registration card. The purchaser must contact ROADMASTER, Inc. prior to returning any product so that ROADMASTER may determine the nature and extent of the claim and to obtain a return authorization number. Returned products must include the return authorization number and a copy of the sales slip as proof of purchase. The date of purchase must coincide with the original warranty registration card on file. If return of the product is required, it must be shipped prepaid UPS to ROADMASTER, Inc. at the address listed below.

ROADMASTER, INC.

5602 N.E. SKYPORT WAY

PORTLAND, OR 97218

1-800-669-9690

ROADMASTER LIMITED WARRANTY

ROADMASTER, Inc. warrants to the original retail purchaser-consumer of this product that such product when used for its normal intended purposes is free of defects in workmanship and materials. This warranty, together with any and all warranties implied by law, shall be limited to a duration of one (1) year from the date of purchase by the original retail purchaser-consumer and is not transferable.

This warranty only covers failures due to defects in materials or workmanship which occur during normal and proper use and does not cover damage which occurs in shipment, backing up with "towed" vehicle attached or failures which are caused by products not supplied by ROADMASTER, Inc. or failures which result from normal wear, misuse, abuse, neglect, mishandling, misapplication, faulty installation, setup adjustments, improper maintenance, alteration, maladjustment, modification, commercial use or service of the product by anyone other than ROADMASTER, Inc.. Furthermore, this warranty does not apply to any product or material or part which has been installed, maintained or used contrary to the operating, maintenance or installation instructions and shall not apply to any parts or materials used in the installation that were not supplied with the product in the original carton or to any damage which said parts or materials may cause.

THIS WARRANTY DOES NOT COVER, AND IS INTENDED TO EXCLUDE, ANY LIABILITY ON THE PART OF ROADMASTER, INC., WHETHER UNDER THIS WARRANTY OR UNDER ANY WARRANTY IMPLIED BY LAW, FOR ANY INCIDENTAL OR CONSEQUENTIAL DAMAGES. SOME STATES DO NOT ALLOW THE EXCLUSION OR LIMITATION OF INCIDENTAL OR CONSEQUENTIAL DAMAGES, SO THE ABOVE LIMITATION OR EXCLUSION MAY NOT APPLY TO YOU.

RESPONSIBILITY OF ROADMASTER, INC.

With proof of date of purchase by the consumer, ROADMASTER's responsibility under this warranty shall be limited to the repair or replacement (at its option) of any product or part which is actually defective at no charge to the consumer except for shipping and/or mailing charges. In no event shall ROADMASTER's liability under any claim or theory exceed the purchase price of the equipment in respect of which damages are claimed. No agent, representative, dealer or employee has the authority to alter or increase the obligations or limitations of this warranty.

RESPONSIBILITY OF THE PURCHASER

In order to qualify for this warranty, the purchaser must completely fill out and, within thirty (30) days of purchase, send to ROADMASTER, Inc. the attached warranty registration card. The purchaser must contact ROADMASTER, Inc. prior to returning any product so that ROADMASTER may determine the nature and extent of the claim and to obtain a return authorization number. Returned products must include the return authorization number and a copy of the sales slip as proof of purchase. The date of purchase must coincide with the original warranty registration card on file. If return of the product is required, it must be shipped prepaid UPS to ROADMASTER, Inc. at the address listed below.

ROADMASTER, INC.

5602 N.E. SKYPORT WAY PORTLAND, OR 97218
1-800-669-9690



OFFICIAL WARRANTY REGISTRATION CARD

(FILL OUT & MAIL WITHIN 30 DAYS OF PURCHASE)

(PLEASE PRINT)

NAME: _____

ADDRESS: _____

CITY: _____ STATE: _____ ZIP: _____

PHONE: () _____

DATE: _____

TOW BAR
PURCHASED
FROM: _____

Dealer Name

ADDRESS: _____

CITY: _____ STATE: _____ ZIP: _____

PURCHASE PRICE: \$ _____

TOW BAR SERIAL #: 091095

VEHICLE TO BE TOWED: (STOWMASTER MOUNTED)

MAKE: _____ YEAR: _____

MODEL: _____

SHIFT:
AUTOMATIC STANDARD 4WD

TOWING VEHICLE INFORMATION: (e.g. MOTORHOME)

MAKE: _____ CLASS: _____

MODEL NAME: _____ YEAR: _____

INSTALLER INFORMATION:

BUS. NAME: _____

ADDRESS: _____

CITY: _____ ST: _____ ZIP: _____

PHONE: () _____

Please FILL OUT COMPLETELY. The above information will enable the factory to expedite any future claim, update or recall that may arise as promptly as possible. THANK YOU

ROADMASTER, INC.

PLEASE PRINT

PLEASE PRINT